

DO NOT SCALE FROM DRAWING. IF IN DOUBT: ASK

UNLESS OTHERWISE SPECIFIED, ALL DIMENSIONS ARE IN MILLIMETRES

BEWARE OF 100mm MEASURING ERROR

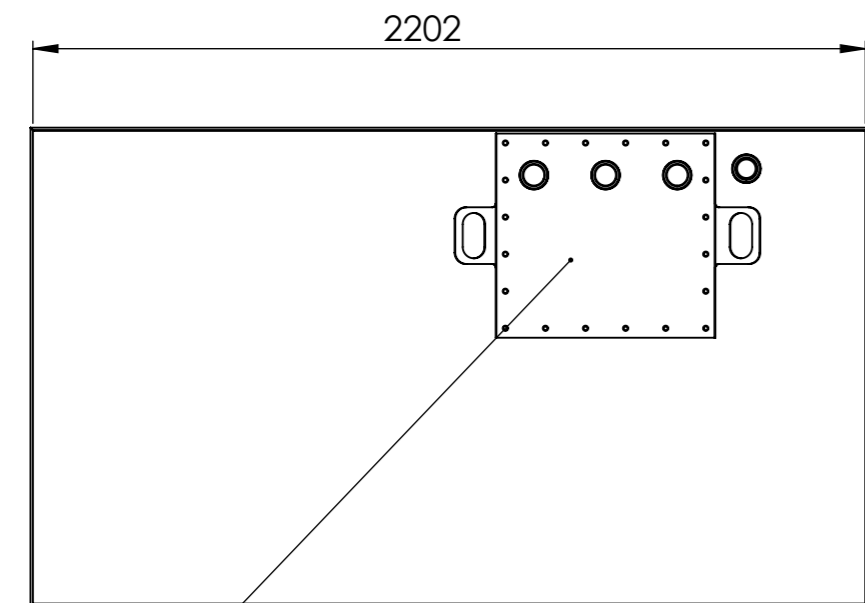

MANWAY

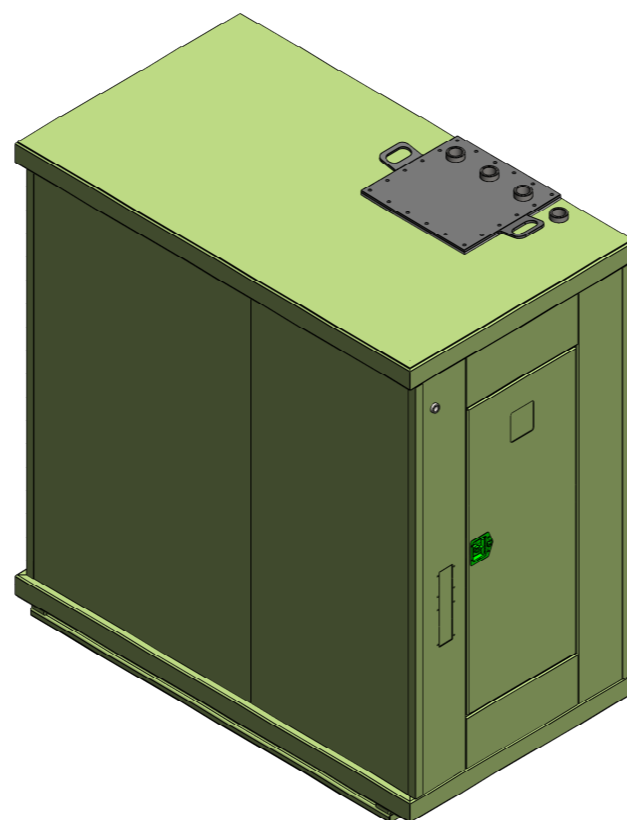

TANK DATA	
TANK CONTENTS:	DIESEL
DESIGNED TO:	AS1940
BUILT TO:	AS1692,CAT.3
CORROSION ALLOW.	0mm
GROSS VOLUME:	5000 L
HYD.TEST PRESSURE:	Gross level+150mm
SAFE FILL LEVEL	4850 L
COLOUR	WHITE
TOTAL MASS:	1490 KG

NOTES.

- 80LPM DISPENSING
- SPIN ON FILTER
- 1 INCH DISPENSE HOSE WITH AUTO NOZZLE
- 240 VOLT POWER
- 2000 USER FMS OR MECHANICAL REGISTER

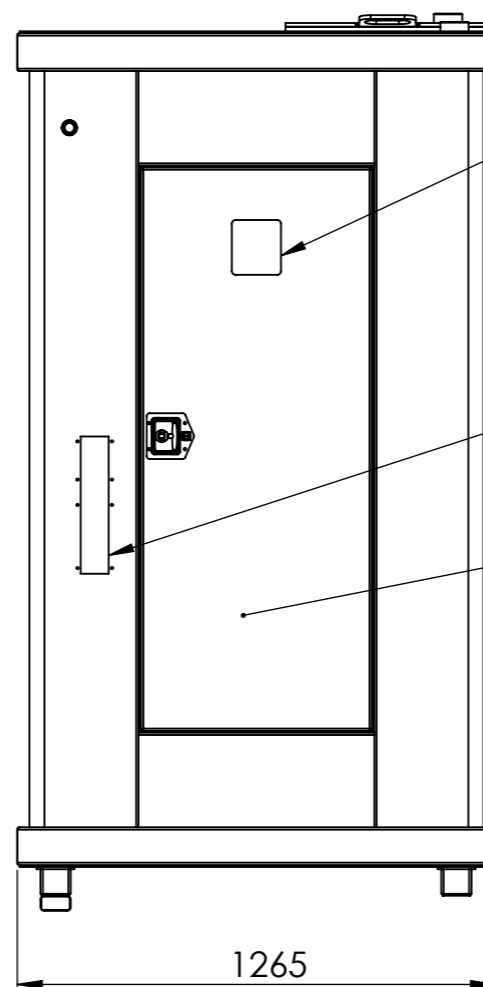
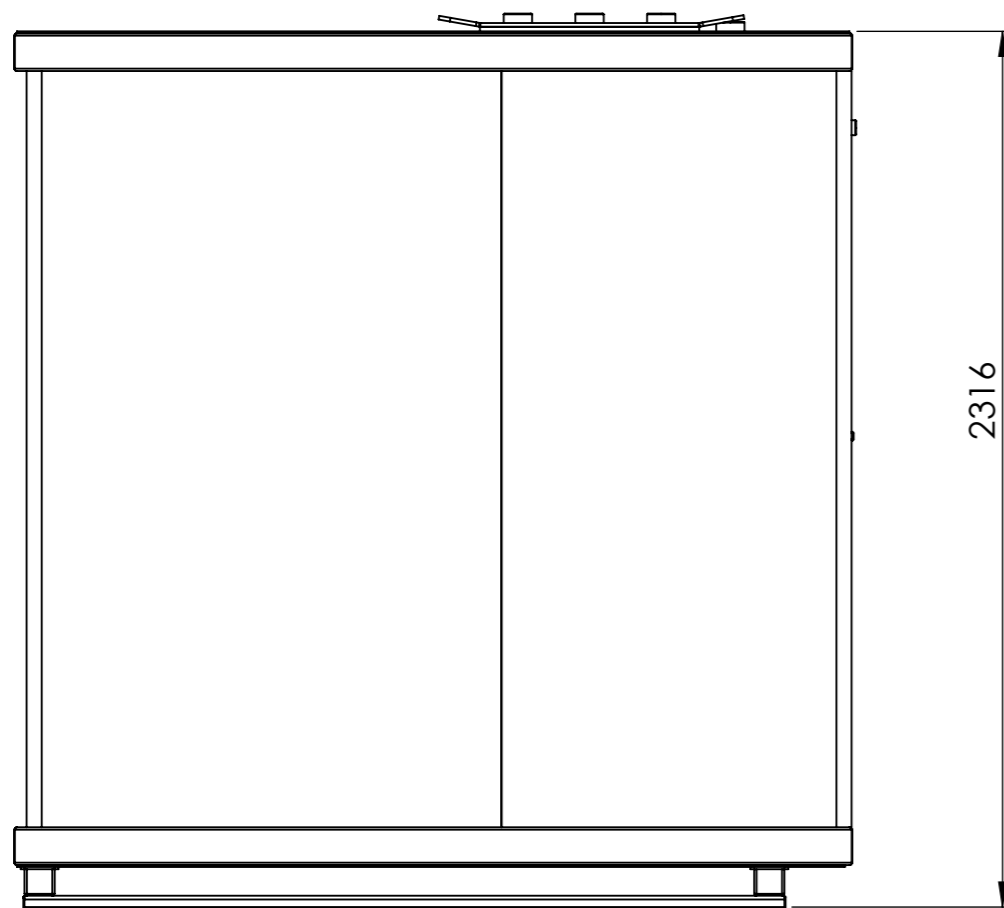

FMS KEYPAD OR MECHANICAL DISPLAY

ALUMINIUM NOZZLE HOLSTER

LOCKABLE DOOR TO FILL POINT AND SWITCHBOARD



THIRD ANGLE PROJECTION

COPYRIGHT © 2014
THE CONTENTS OF THIS DRAWING
REMAINS THE PROPERTY OF
GLOBAL ENGINEERING SOLUTIONS.
CONTENTS MAY NOT BE
COPIED OR REPRODUCED UNLESS
PREVIOUSLY AUTHORISED



Regus Shui On 2/F
Shui On Centre
6-8 Harbour Road
Wanchai Hong Kong

TITLE: 5000 L Farm Tank

DRAWN BY: S.lowrie

SHEET 1 OF 1

DATE: 10/01/2017

SCALE: N.T.S.

CUSTOMER: GES

TOLERANCE U.N.O.
0 = +1.0
0.0 = +0.4
0.00 = +0.1

DWG NO. / PART NO.
5000 Litre Farm Refuel

SHEET SIZE
A3

WEIGHT: 1490.00 Kg

MATERIAL:

REVISION